



CREST
ULTRASONICS
THE INNOVATION CONSTANT™

Ultrasonic Tanks, Generators, Immersible And Push Pull Transducers

Precision Cleaning With Ultrasonics



PRECISION CLEANING WITH ULTRASONICS

The Ultrasonic Cleaning Process

Ultrasonic energy placed in liquid causes alternating patterns of low and high pressure phases. During the low pressure phases, minute bubbles form. During the subsequent high pressure phases, the bubbles implode violently. This process is called cavitation.

Cavitation provides an intense scrubbing action that leads to unsurpassed cleaning speed and consistency when compared with simple soaking or immersion with agitation. Additionally, the minute bubbles formed penetrate even microscopic crevices, cleaning them thoroughly and consistently. As a result, ultrasonic cleaning is one of the most highly effective and efficient methods for cleaning a wide array of parts, even in mass-production environments.



Tank, Genesis generator and immersible transducers.

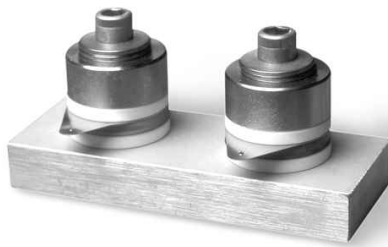

Vibra-Bar Transducers - 40 kHz

These specially bonded, durable transducers offer enhanced cleaning performance. The Vibra-Bar design consists of two transducer stacks which permit simultaneous multiple frequencies. They are available in the form of transducerized tanks and separate immersibles which are fully sealed so they can be inserted into an existing tank to convert it into an ultrasonic cleaning system.

316L Stainless Steel Tanks Welded Inside and Out

- Provides the optimum environment for precision cleaning with extended service life
- Constructed of cavitation resistant, bright annealed 316L stainless steel
- Welded inside and out for long-term stability and sturdy performance
- Cove corner construction with ground and polished welds available
- Sloped bottoms for easy draining

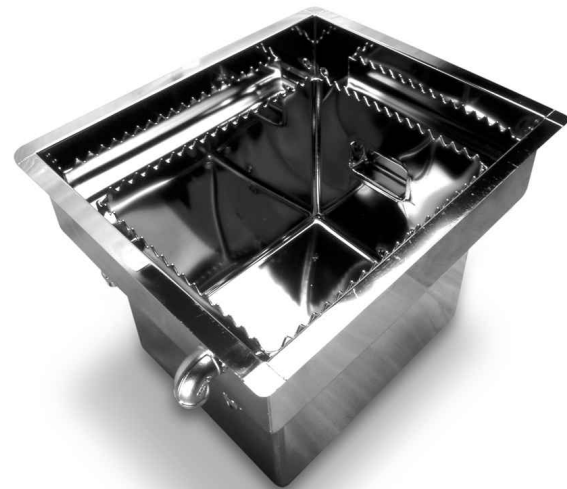

TRANSDUCERIZED TANK

Model No. (Heater)	Capacity (Gallons)	Internal Dimensions W x L x D Inches Centimeters	Overall Dimensions W x L x H Inches Centimeters	Power Req. (heated tank)	Generator Required
XHT-710-3	3	7 x 10 x 10 17.8 x 25.4 x 25.4	10 x 13 x 14.5 25.4 x 33 x 36.8	120V / 4.2A / 500W	250W
XHT-1014-6	5	10 x 14 x 10 25.4 x 35.6 x 25.4	13 x 17 x 14.5 33 x 43.2 x 36.8	120V / 8.4A / 100W	500W
XHT-1218-9	10	12 x 18 x 12 30.5 x 45.7 x 30.5	15 x 21 x 16.25 38.1 x 53.3 x 41.4	240V / 8.4A / 2000W	750W
XHT-1524-12	19	15 x 24 x 14 38.1 x 61 x 35.6	18 x 27 x 18.75 45.7 x 68.6 x 47.8	240V / 12.6A / 3000W	1000W
XHT-1622-12	22	16 x 22 x 16 40.6 x 55.9 x 40.6	19 x 25 x 20.75 48.3 x 63.5 x 52.7	240V / 12.6A / 3000W	1000W
XHT-1826-18	33	18 x 26 x 18 48.7 x 66 x 45.7	21 x 29 x 22.75 53.3 x 73.7 x 57.9	240V / 16.8A / 4000W	1500W
XHT-2426-30	49	24 x 26 x 20 61 x 66 x 50.8	27 x 29 x 24 68.6 x 73.7 x 61	240V / 21A / 5000W	2500W
XHT-2436-42	68	24 x 36 x 20 61 x 91.4 x 50.8	27 x 39 x 24 68.9 x 99 x 61	240V / 34A / 8000W	3500W
XHT-2446-54	86	24 x 46 x 20 61 x 116.8 x 50.8	27 x 49 x 24 68.9 x 124.5 x 61	240V / 42A / 10,000W	4500W
XHT-1236-24	34	12 x 36 x 20 30.5 x 91.4 x 50.8	15 x 39 x 24 38.1 x 99 x 61	240V / 17A / 4000W	2000W
XHT-1246-30	43	12 x 46 x 20 30.5 x 116.8 x 50.8	15 x 49 x 24 38.1 x 124.5 x 61	240V / 21A / 5000W	2500W

Notes:

- All tanks have 1" (2.54cm) wide flange around top edge. Flange not included in overall dimensions.
- Prefix X in model number should be substituted with a 2 (for 25 kHz), 4 (for 40 kHz), 5 (for 58 kHz), 6 (for 68 kHz), 13 (for 132 kHz) or 19 (192 kHz) when ordering.
- HT stands for Heater Tank.
- NT stands for non-Heater Tank.

Options:

- Stainless steel tank cover • Overflow weir • Recirculating filter system (brass or stainless steel) • Sealed skirts • Stainless steel work basket • Cove corner construction
- Matching rinse tank - no transducers (heated or unheated) • Different voltages • Water jacket • Ground and polished welds • ChemCrest chemicals • Sound dampening
- Condensing collar • Custom sizes • Drain valve - ball type (brass or stainless steel) • Oil Skimmer / Decanter • Custom sizes • Hard Chrome

IMMERSIBLE TRANSDUCERS

Model*	Mounting Types Available*	Dimensions (W x L x H) Inches Centimeters	Generator Required
XCI-320-3	FC, EB, DBB, FL	3.5 x 20 x 3 8.9 x 50.8 x 7.6	250W
XCI-710-3	FC, EB, BB, FL	7 x 10 x 3 17.8 x 25.4 x 7.6	250W
XCI-720-6	FC, EB, DBB, FL	7 x 20 x 3 17.8 x 50.8 x 7.6	500W
XCI-817-6	FC, EB, DBB, FL	8 x 17 x 3 20.3 x 43.2 x 7.6	500W
XCI-1218-12	FC, DBB, FL	12 x 18 x 3 30.5 x 45.7 x 7.6	1000W
XCI-732-12	FC, DBB, FL	7 x 32 x 3 17.8 x 81.3 x 7.6	1000W

Notes:

- When ordering, add mounting type desired as model suffix (e.g. 4CI-710-3-EB)
- FC: Flexible cable or Braided hose, - EB: End Bulk head,
- DBB: Double Base Bulk head, - FL: Flange / plate mounting
- Prefix X in model number should be substituted with a 2 (for 25 kHz), 4 (for 40 kHz), 5 (for 58 kHz), 6 (for 68 kHz), 13 (for 132 kHz) or 19 (for 192 kHz) when ordering
- The dimension of ultrasonics immersible is denominated in the model as follow:
i.e. XCI-710-3 the dimension is 7" (width) x 10" (length)
- Height listed is for 40 kHz, 58 kHz, 68 kHz, 132 kHz & 192 kHz. Height for 25 kHz is 4" (10.2 cm)

Options:

- Titanium nitride coating
- Hard chrome
- Custom sizes

Generators

Crest Genesis™, Generators

- Outstanding and consistent performance, process control and the ability to monitor output for consistent cleaning time after time
- Tru-Sweep™ sweep frequency eliminates inconsistent cleaning by sweeping a +/- 1 kHz around the center frequency at a set repetitive rate
- Standard two power options to vary cleaning from gentle for delicate parts to periodic short blasts of power for hard to clean parts
- 3 controls including Amplitude control to vary ultrasonic power, Duty Cycle Control to control the amount of ultrasonic energy delivered and Frequency control to adjust the frequency of the ultrasonic energy reducing audible noise from subharmonics
- Available in 25, 40 or 68 kHz frequencies and in either 250 or 500 watt models

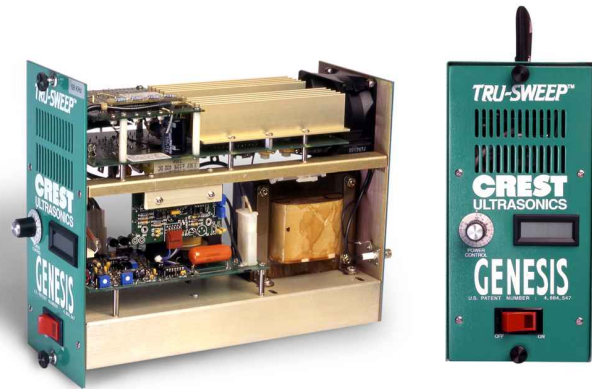

Model	Power Output (watts)	Max. Power Input 120V/50-60 Hz	Dimensions L x W x H Inches Centimeters	Number of Plug-in Modules
XG-250-3	250	3A / 360W	5.25 x 14 x 12 13.3 x 35.6 x 30.5	1
XG-500-6	500	5A / 600W	5.25 x 14 x 12 13.3 x 35.6 x 30.5	1
XG-750-9	750	8A / 960W	10.5 x 14 x 12 26.7 x 35.6 x 30.5	2
XG-1000-12	1000	10A / 1200W	10.5 x 14 x 12 26.7 x 35.6 x 30.5	2
XG-1500-18	1500	15A / 1800W	15.8 x 14 x 12 40.1 x 35.6 x 30.5	3
XG-2000-24	2000	20A / 2400W	21 x 14 x 12 53.3 x 35.6 x 30.5	4

Notes:

- Prefix X in model number is for 2 for 25 kHz and 4 for 40 kHz and also 6 for 68 kHz
- Last digits in model number indicate the number of Vibra-Bars on the unit
- The generator is the units of 250 watts or 500 watts.
i.e. for 1000 watts generator, it consists of 2 units of XG-500-6.

Standard features:

Amplitude Control Sweep Frequency

Options:

- Adjustable sweep frequency
- Timer: 0 - 30 minutes
- Other input voltages
- Nema 12 enclosure
- Remote power control
- Sealed generator - coated and with a heat sink
- CWF watt frequency meter (generator mounted or remote)
- Power Intensity control-duty cycle type
- Single channel computer interface (power monitor and control)
- Three channel computer interface (amplitude, duty cycle, frequency control and power monitor)

Generators

Crest Martin Walter Powersonics Generators

The technology

By using the latest semiconductor technology, complex integrated circuits and robust power electronics, we are able to supply a series of modular generators which meet all the requirements of industrial users in full. Thanks to their exceptional compactness, they require very little space, even in complex plants.

Technical highlights:

- Every module is an autonomous ultrasound generator (i.e. independently functional)
- New-type output stage ensures high degree of efficiency > 95%
- Stable at no-load, i.e. even if a resonator is not connected, the generator is not damaged
- Short-circuit proof, overload proof
- Automatic impedance and frequency adjustment
- Output power adjustable between 40% and 100% of the nominal output of the ultrasound generator
- Preset output power automatically held constant
- Monitoring and display of effective ultrasound output. Status display on every generator module
- Wide variety of options for remote control and monitoring of the individual modules permitted by the interface supplied as standard
- The interface offers the following options:
 - Modules can be switched on / off independently
 - Output power from the individual generator modules
 - Can be remotely adjusted independently
 - Individual monitoring of outputs by means of 0-10 volts signal
 - Monitoring of all fault conditions by integral relay
 - Comprehensive facilities for programming to meet
 - Customers' specific requirements

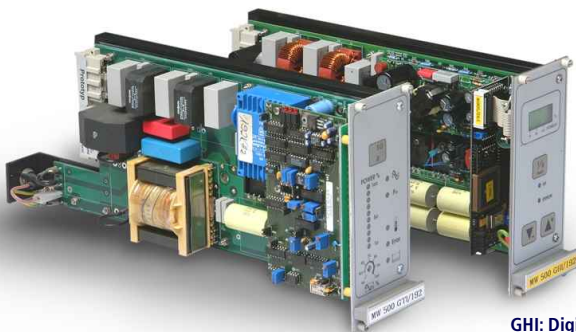

GTI: Analog type

GHI: Digital Type



Generator

Generator Model No.	Power Output (Watts)	Max. Power Input Volts / Frequency
XMW 500 GTI or GHI	500	240 V / 50 or 60 Hz

Housing Type

Type	Dimension L x W x H Inches Centimeters	Power Supply	Number of Plug-in Modules
28 TE	15 5/8 x 7 1/4 x 7 5/8 39.7 x 18.4 x 19.4	Single phase	1
42 TE	16 3/16 x 9 9/32 x 8 3/4 41.1 x 23.6 x 22.2	Single phase	2
84 TE	16 3/16 x 17 5/8 x 8 3/4 41.1 x 44.9 x 22.2	3-phase	5

Notes:

- Prefix X in model number is for 5 for 58 kHz, 13 for 132 kHz and 19 for 192 kHz.
- GTI: Analog type
- GHI: Digital Type
- The Generator is the unit of 500w. i.e. for 1000w MW 1000 GTI, it consists of 2 units of MW 500 GTI or GHI.

Standard features:

- External On / Off 25-pole SUBD plug
 - Potential free contact
 - Maximum load of the contact are 30 V and 30 mA



Watt Frequency Meters (CWF 200)

Crest Watt Frequency (CWF) Meters, available mounted on the generator, hand held, or remote, directly measure the ultrasonic energy being fed into the transducers of the tank. The power and frequency are digitally displayed. This controls mechanism assures the user of consistent and repeatable results.



Chem Crest™ Detergent

Improve the cleaning power of any ultrasonic device with ChemCrest Cleaning Chemicals. Crest has developed a line of detergents specially formulated for use in ultrasonic cleaners. They were designed to yield the best possible cleaning results in specific cleaning applications. We prefer to discuss the specifics of our customer's applications before making a recommendation. Please contact us today for a recommendation for your individual application.

CREST SUPPORT

Optimizing ultrasonics for you



Applications Expertise and Field Service Just a Phone Call Away

At Crest, the best ultrasonic cleaning process for your application is developed in a Class 100 clean room applications lab. Its expert staff is always on hand to answer your application questions and give recommendations.

We maintain sales and service offices worldwide so we can respond quickly to your needs. All Crest ultrasonic cleaning equipment is easily installed, and designed for high performance and low maintenance by our engineering staff, the largest in the industry.



The Best Guarantees in the Industry

How confident are we of your satisfaction - and success - with Crest ultrasonic cleaning equipment? Confident enough to offer you the most comprehensive guarantees available on generators, transducers and tanks!

We guarantee you of defect-free workmanship and the performance reflective of state-of-the-art technology for a period of two years on generators, 10 years on transducers bonding and one year on tanks.

PUSHPULL® - A UNIQUE ULTRASONICS TECHNOLOGY For Precision Cleaning And Sonochemistry

PushPull® transducers

PushPull® transducer - a resonating system opens up new opportunities for ultrasonic cleaning in a number of areas in which ultrasonic could previously only be used with difficulty or not at all.

The ultrasonic driverheads mounted at both ends of the resonator rod induce longitudinal pulses in the resonator at the points of attachment. Even with increasing length of the resonator the longitudinal pulses guarantee a homogenous sonic field.

The following frequencies are available:

25 kHz, 30 kHz, 40 kHz and 45 kHz.

We offer the PushPull® transducer in different materials so we can act to different needs.

Advantages:

- Exceptionally long life time assured by solid resonator
- Very high efficiency (>97%)
- This permits cost savings through the reduction in energy consumption
- Installation in vacuum or overpressure environment possible
- Automatic internal identification for dry-running condition without additional wiring

Multi-purpose, flexible use

The PushPull® technology comes into its own in the following applications:

- Ultrasonic cleaning
- Environmental applications (e.g. sewage sludge treatment)
- Sonochemistry (supporting chemical processes)
- Emulsifying and dispersing



Patented by Martin Walter in 1989, the push-pull resonator represents a new method of introducing ultrasonics energy into liquid media.



SinglePush® transducers

The SinglePush® transducer with only one driverhead is the less expensive version of the PushPull® transducer. Only one driverhead has to create the total power.

System Configuration

Transducer	Frequency (kHz)	Watts (w)
SinglePush®	25 kHz	600w, 1000w, 1500w, 2000w
	30 kHz	600w, 1000w, 1200w
PushPull®	25 kHz	600w, 1000w, 1500w, 2000w, 2500w
	30 kHz	600w, 1000w, 1500w
	40 kHz	300w, 500w, 750w, 1000w
	45 kHz	500w, 750w, 1000w

CREST ULTRASONICS INDIA PVT. LTD

Plot No. 185, Ground Floor, Functional Industrial Estate,
Patparganj, Delhi-110092, India

Phone: +91-11-4054 6323, +91-11-2216 4532

E-mail: info@crestultrasonicsindia.com

Website: www.crestultrasonicsindia.com

Crest Ultrasonics

Scotch Road,
P.O. Box 7266, Trenton,
NJ 08628 USA.

Tel: (609) 883 4000

Fax: (609) 883 6452

Toll Free: 1-800-992 7378

E-mail: info@crest-ultrasonics.com

Website: www.crest-ultrasonics.com



Factory in Penang, Malaysia. • Tel: +604-507 0018 • Fax: +604-507 0020 • www.crestm.com

CORPORATE HEADQUARTERS **USA** MANUFACTURING LOCATIONS **USA • MALAYSIA • SWITZERLAND • GERMANY • UNITED KINGDOM • FRANCE**
SALE & SERVICE OFFICES **THAILAND • JAPAN • KOREA • PHILIPPINES • SINGAPORE • FRANCE • CHINA** AGENTS **USA • HONG KONG • CHINA**
• **AUSTRALIA • TAIWAN • KOREA**

INTERNATIONAL LOCATIONS **Uthe California** 252 Great Mall Parkway, Milpitas, CA 95035 USA. Tel: 408-945 8894 Fax: 408-945 1556
Crest Ultrasonics Malaysia Plot 121, Jalan Perusahaan, Bukit Tengah Industrial Park, 14000 Bukit Mertajam, Penang, Malaysia. Tel: 604-507 0018
Fax: 604-507 0020 **Crest Ultrasonics Thailand** SV City 916/270 Rama III Rd, Banpongpan, Yannawa, Bangkok, 10120 Thailand. Tel: 662-682 6506
Fax: 662-682 6507 **Crest Ultrasonics Singapore** 66 Tannery Lane #01-04D, Sindo Building, Singapore 347805. Tel: 65-741 8266 Fax: 65-741 1939
Crest Ultrasonics Philippines 2F Goodwill Building 393 Sen. Gil J. Puyat Avenue Makati City, Philippines. Tel: 632-898 3561 Fax: 632-898 3575
Uthe Japan 1-8-15 Nakagawa Kohoku-Ku Yokohama, 223 Japan. Tel: 81-45 912 7911 Fax: 81-45 912 7921 **CC Hydrosonics Ltd.** Italstyle Factory,
Cambridge Road, Harlow, Essex CM20 2HE, U.K. Tel: 44-1279 418 942 Fax: 44-1279 453 926 **Martin Walter Ultraschalltechnik AG** Hardstraße 13,
D-75334 Straubenhardt, Germany. Tel: 49-708 279 1501 Fax: 49-708 279 1515 **Rinco Ultrasonics AG** Industriestrasse 4 / P.O. Box CH - 8590
Romanshorn, Switzerland. Tel: 41-71 461 1622 Fax: 41-71 461 1666 **Crest Ultrasonics Shanghai** Unit 902A, Hong Li Da Building, No. 50, Nan Bai
Yan Jie Suzhou Industrial Park, Suzhou, Jiangsu Province, PRC. Postal code: 215006. Tel: +86 512 6288 4907 Fax: +86 512 6288 4909. **Taiwan / Korea:**
Please enquire for Crest Ultrasonic representative contact @ 604-507 0018.